

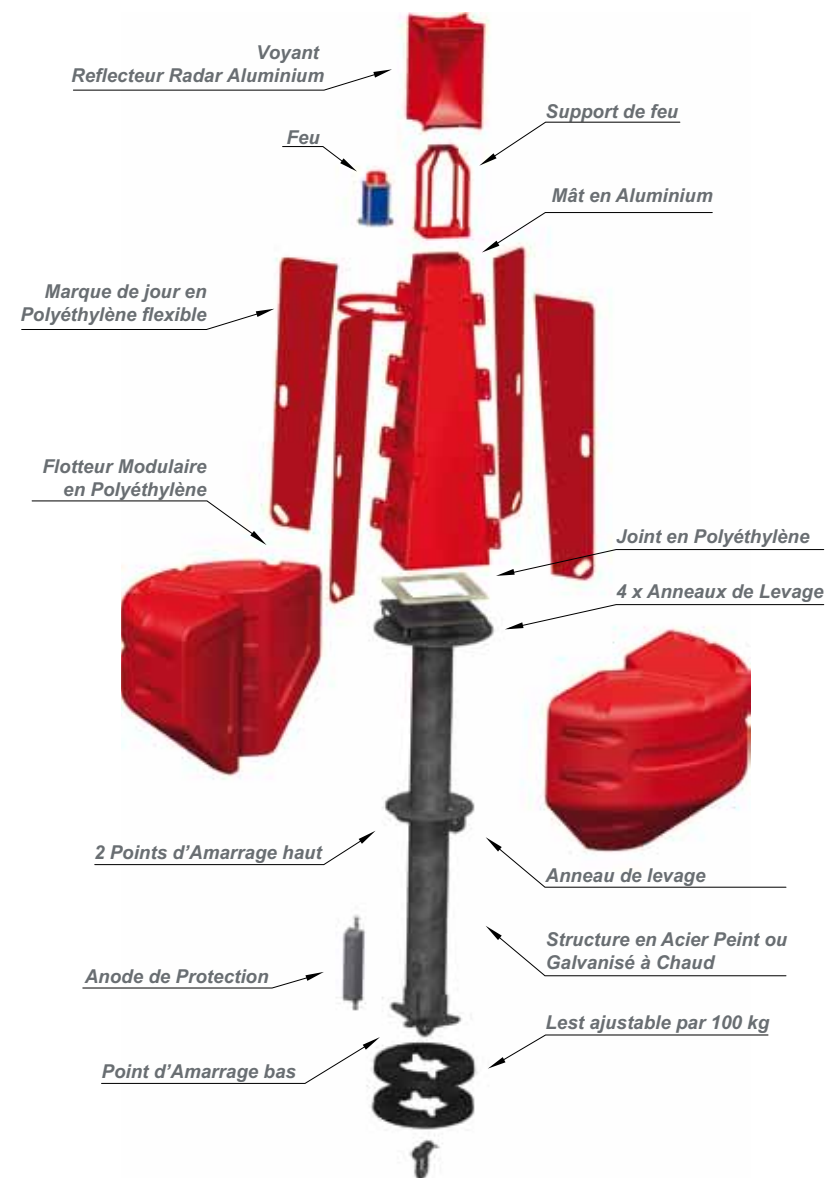

SPÉCIFICATIONS	Q	Q PE	Q STA
POIDS AVEC LEST (t)	0,9	0,8	0,8
FLOTTABILITÉ (kg/cm)	25	25	25
SURFACE VISIBLE (m²)	4,5	2,2	2,07

DIMENSIONS (m)	Q	Q PE	Q STA
Ø : Diamètre	1,9	1,9	1,9
PF : Plan focal	3,1	2,6	2,6
TE : Tirant d'eau	2,3	2,4	2,3
FB : Franc bord	0,6	0,6	0,6
HHT : Hauteur hors tout	6,3	4,9	4,9
A : Mât	2,0	1,6	1,6
B : Hauteur de flotteur	1,2	1,2	1,2
C : Structure	3,0	3,0	3,0
D : Diamètre de structure	0,3	0,3	0,3
E : Largeur hors tout du mât	1,5	—	0,7
F : Largeur hors tout de structure	0,8	—	1,0
G : Marque de jour	0,7	—	—
H : Support de feu	0,6	—	—
I : Feu	—	0,3	0,3
J : Voyant	—	1,2	—
K : Diamètre du mât	—	0,5	—
L : Diamètre du voyant	—	1,0	—



Vue éclatée d'une JET 2500 Q PF3 STD

Les éléments de mouillage (manilles, chaînes, émerillons, corps-morts) sont disponibles dans la section mouillage du catalogue.

# JET 2500 Q PF3 / 2.5

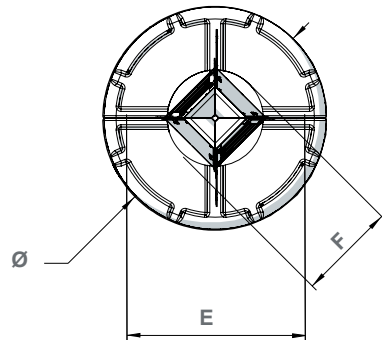
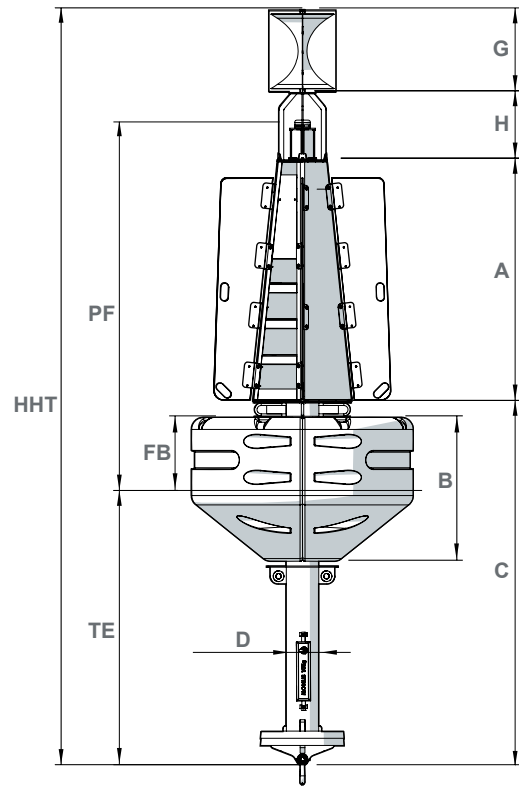

JET 2500 Q PF3 STD

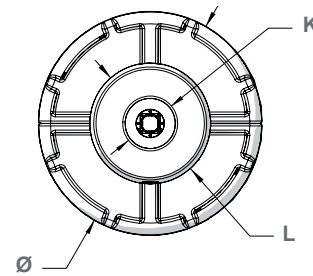
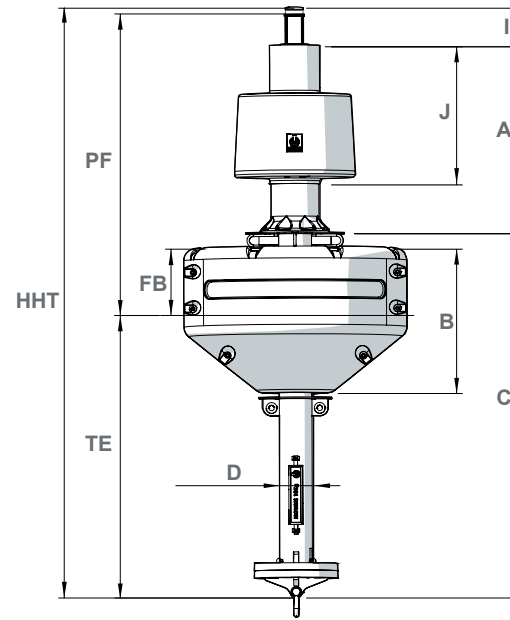

JET 2500 Q PF2.5

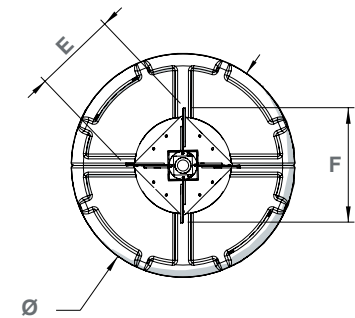
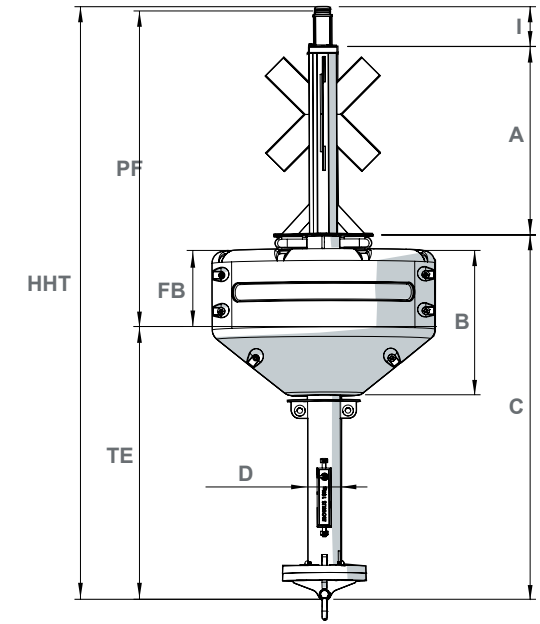

JET 2500 Q PF2.5

Les photos et illustrations publiées sont non contractuelles.



SPECIFICATIONS	Q	Q PE	Q STA
WEIGHT WITH BALLAST (t)	0,9	0,8	0,8
BUOYANCY (kg/cm)	25	25	25
VISIBLE SURFACE (m²)	4,5	2,2	2,07

DIMENSIONS (m)	Q	Q PE	Q STA
Ø : Diameter	1,9	1,9	1,9
FP : Focal Plane	3,1	2,6	2,6
TE : Draught	2,3	2,4	2,3
FB : Freeboard	0,6	0,6	0,6
OH : Overall Height	6,3	4,9	4,9
A : Mast	2,0	1,6	1,6
B : Float height	1,2	1,2	1,2
C : Structure	3,0	3,0	3,0
D : Diameter of structure	0,3	0,3	0,3
E : Overall width of mast	1,5	—	0,7
F : Overall width of structure	0,8	—	1,0
G : Topmark	0,7	—	—
H : Light support	0,6	—	—
I : Light	—	0,3	0,3
J : Daymark	—	1,2	—
K : Diameter of mast	—	0,5	—
L : Diameter of daymark	—	1,0	—

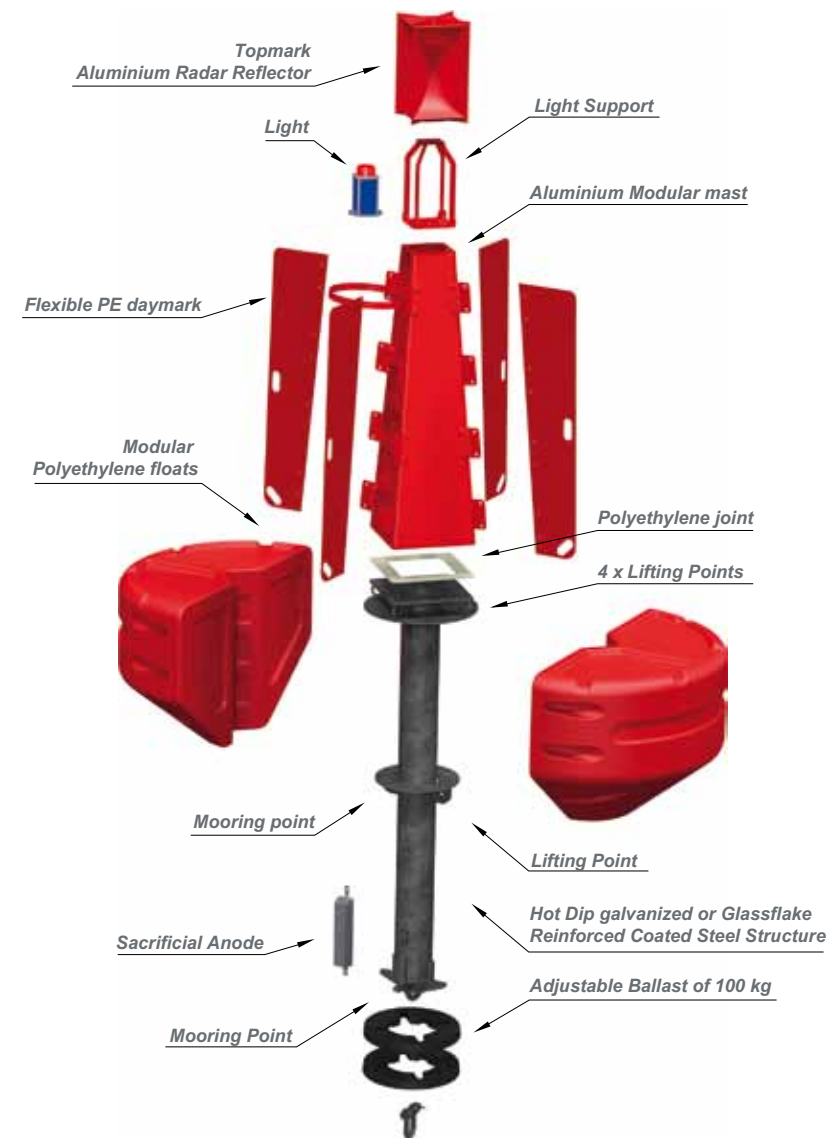

JET 2500 Q PF3 STD exploded view

Anchoring elements (skackles, chains, swivels, sinkers) are available in the mooring accessories section in the catalogue

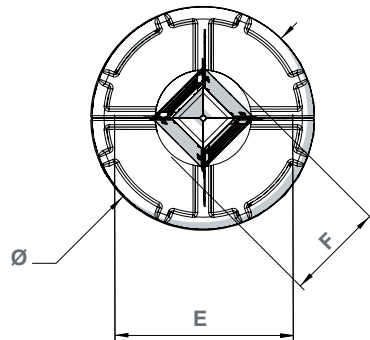
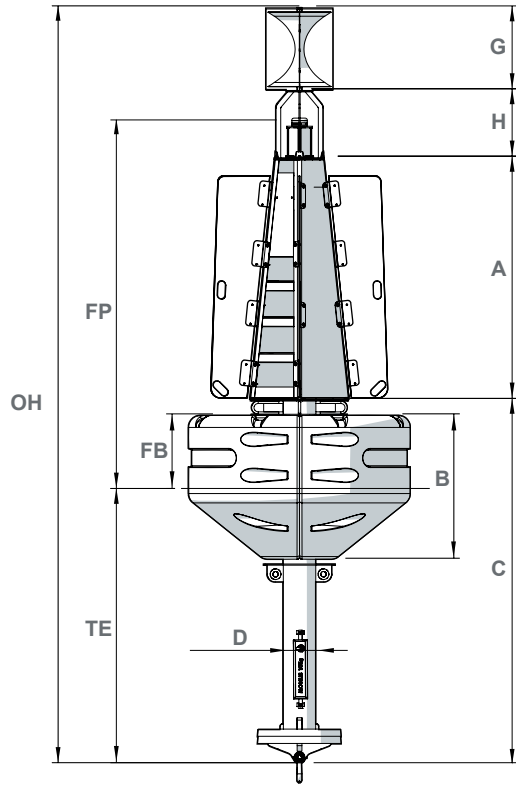

JET 2500 Q STD

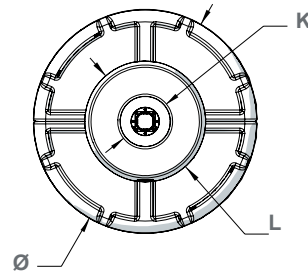
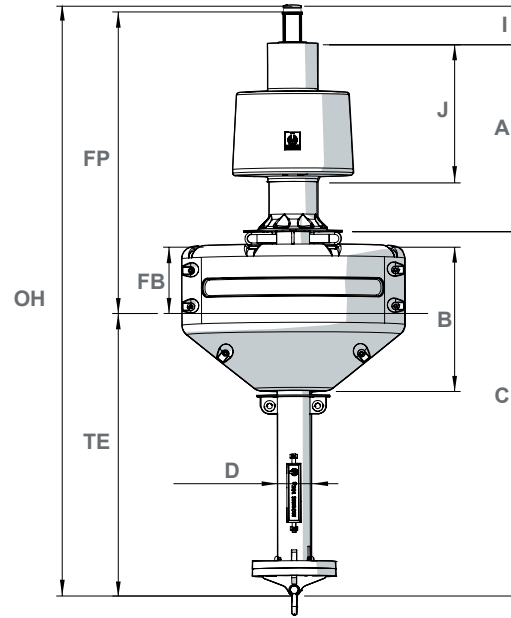

JET2500 Q PF2.5 VPE

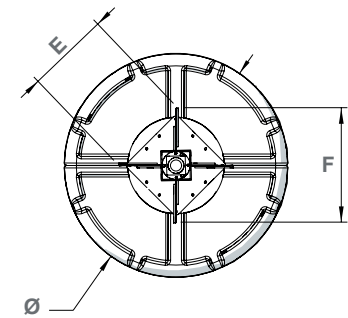
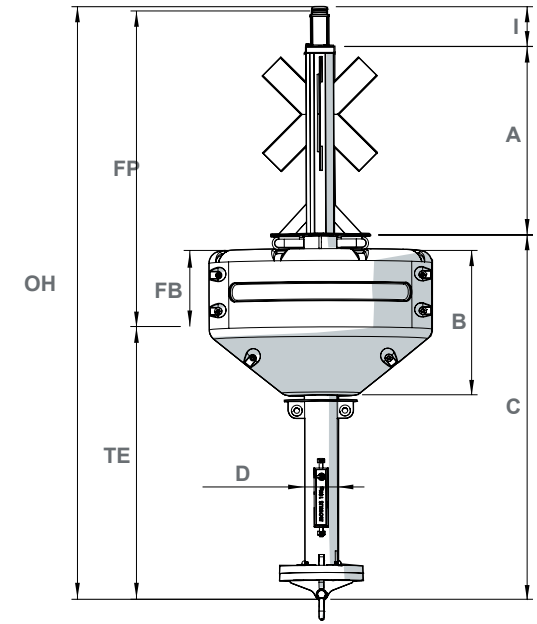

JET2500 Q PF2.5 VMO

Non-contractual illustrations and photos