



ERGL

SOLAR ELEVATED RUNWAY GUARD LIGHT

Carmanah's Solar Elevated Runway Guard Light (ERGL) provides a distinctive warning to pilots that they are approaching a runway holding position and are about to enter an active runway. The ERGL has a high intensity LED light source and is powered by our industry leading solar engine power supply (SEPS).



- Provides 24-hour unidirectional marking at runway and taxiway intersections
- Installs in minutes and can be relocated just as quickly
- Includes LED lights, frangible column and tether
- Fixture flash-rate is controlled from an intelligent lighting control system module located in the SEPS; alternating flashes, 45-50 per minute
- Can be aimed both vertically and horizontally and has an adjustable Light Beam: 0° to 20° vertically; ±20° horizontally
- Significant reduction of maintenance costs and re-lamping expenses through long-lasting LED technology - average LED life of 56,000 hours under high-intensity conditions and more than 100,000 hours under actual operating conditions
- Engineered for reliable performance, the Energy Management System (EMS) monitors and adapts brightness to environmental conditions for consistent operation and long life under tough conditions
- Autonomy (operation without solar charging) 7+ days - scalable to meet requirements up to 40 days
- Battery life: 5+ years

SEPS Models

The ERGL is available in two SEPS models: Standard and Wireless. With the standard SEPS, the unit will activate automatically between dawn and dusk with pre-set illumination. The wirelessly controlled SEPS allows the unit to be activated remotely via a handheld controller.

Fixture Construction

The ERGL fixture is fabricated from corrosion-resistant materials and all exterior surfaces are painted aviation yellow for added protection and visibility. Includes high-strength ERGL base plate. The two ERGL light sources are surrounded by a black face plate and independent visors to reduce the amount of incident sunlight, thereby maximizing the contrast during the LED ON/OFF cycle.

Installation

ERGL systems are typically installed in pairs with one unit on either side of the taxiway holding position. The ERGL should be installed according to FAA AC 150/5340-30. The SEPS should be installed on a level concrete pad within 20 feet of the ERGL. For a temporary application, the wiring between the SEPS and the ERGL can be above ground. Both the ERGL and SEPS contain side conduits for cabling access.

REPRESENTED IN YOUR REGION BY:

ERGL

SOLAR ELEVATED RUNWAY GUARD LIGHT

OPERATING CONDITIONS

Temperature	-40 °C to +55 °C (-40 °F to +131 °F)
Humidity	0 to 100%
Wind	Withstands wind velocities up to 480 kph (300 mph)

SOLAR ENGINE POWER SUPPLY (SEPS)

Installed weight	59.8 kg (132 lb)
Shipping weight	Box 1 (SEPS) - 34.4 kg (76 lb) Box 2 (battery) - 30.8 kg (68 lb)
Installed dimensions*	759 H x 1089 W x 441 D mm 29.9 H x 42.9 W x 17.4 D in * with wireless antenna at 55° tilt
Shipping dimensions	
Box 1 (SEPS)	647 H x 1191 W x 356 D mm 25.5 H x 46.9 W x 14.0 D in
Box 2 (battery)	210 H x 332 W x 188 D mm 8.3 H x 13.1 W x 7.4 D in
Temperature	
Operating:	-30 to +50 °C (-22 to +122 °F)
Storage:	-40 to +80 °C (-40 to +176 °F)
Chassis	Weather and corrosion-resistant construction of stainless steel and powder coated aluminum
Mounting	Frangible couplings and floor flange mounts
Wind loading	480 kph (300 mph) min. installed at 55° tilt
Tilt	15°, 35°, 55°
Diagnostics	On-board feedback indicators for: Battery Status, System Status, Battery Reverse Polarity, and Solar Panel Reverse Polarity
Certifications	ROHS, WEEE, CE, FCC

BATTERY

Power	12 VDC 105 A-hr at C/100 discharge rate
Type	Replaceable and recyclable, absorbent glass mat (AGM) SLA.
Lifetime	4,000 cycles to 20% depth of discharge at +20°C (+68°F)
Charger	Temperature-compensated, maximum power point tracking (TC-MPPT)

LED DRIVER

Channels	2 independent channels
Channel A:	18 – 38 VDC from 0.3 – 1.4 A and 5 – 100 % duty cycle, constant current
Channel B:	18 – 38 VDC from 0.3 – 1.4 A and 5 – 100 % duty cycle, constant current
Automatic Light Control (ALC)	ALC dynamically reduces brightness in response to unusually low amounts of sunlight to ensure continued autonomous operation. Available on Channels A and B.
Control, Autonomous Mode	Dusk-to-dawn flashing or 24-hour flashing
Load Cabling	6.7 m (22 ft) cable can exit onto the surface or down into a ground pot

PV PANEL

Power	95 W
Type 61215	High Efficiency Monocrystalline, IEC
Lifetime	10 years at 90% output

WIRELESS

Range	4 km (2.5 m)
Frequency	900 MHz ISM Band, FHSS
Encryption	256-bit AES
Control, On-demand Mode	- Seamless integration with existing Carmanah wireless solar products - Up to 8 independent groups. - Flash Mode, Emergency Mode, Autonomous Mode - On-demand Temporary Mode (High, Medium, and Low), Configuration Mode, ARCAL

FIG. 1. SEPS DIMENSIONS

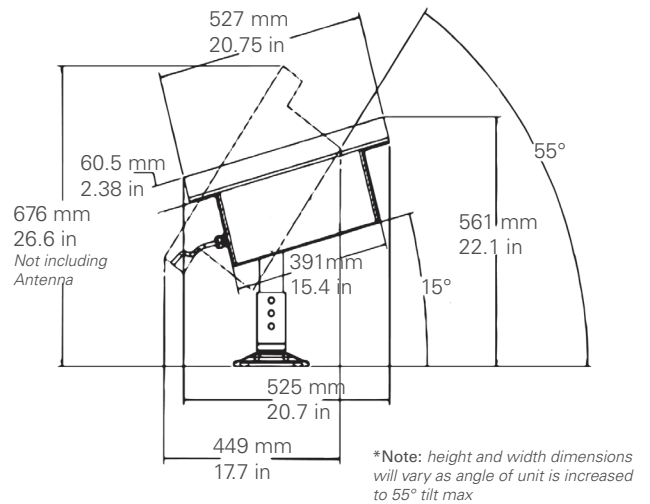
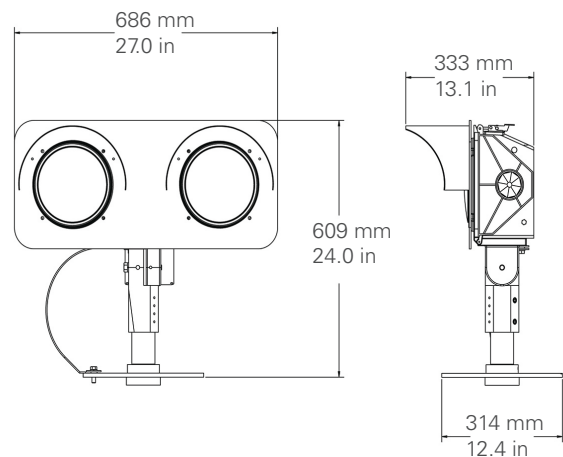

FIG. 2. ERGL DIMENSIONS



The management system governing the manufacture of this product is ISO 9001:2008 certified.

Carmanah is a Canadian public corporation - TSX:CMH

© 2017, Carmanah Technologies Corp.

Document: AVIA_ERGL_Spec_Sheet_RevB

Specifications subject to local environmental conditions.

Specifications may be subject to change.

US and International patents apply. Other patents pending.

"Carmanah" and Carmanah logo are trademarks of Carmanah Technologies Corp.