

SBE 130 EX

Battery Box

The battery box model SBE 130 EX is designed to operate under the most harsh offshore conditions. The robust battery box is constructed from stainless steel with a modular design.

- The standard battery box is equipped with a 130Ah VRLA battery
- Modular design approval gives the opportunity to offer bigger enclosures with bigger batteries
- The enclosure can also be offered with Nickel Cadmium battery
- ATEX category Zone 1 and Zone 2
- The battery box can be used on offshore platforms and on SBM buoys
- The battery box can be equipped with a main switch or with a circuit breaker



External earthing stud on the enclosure



Robust enclosure mounting points



Ventilated lid construction

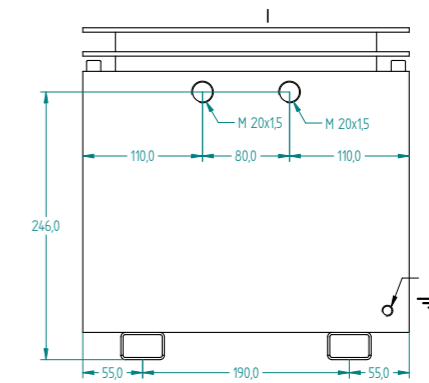
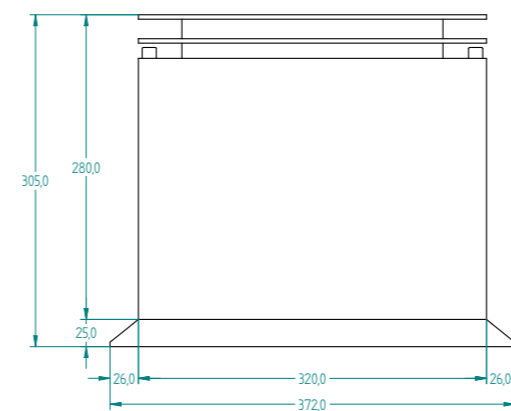

Main Technical Specification

Battery capacity	130Ah
Battery Voltage	12V DC (24VDC)
Degree of protection	IP 23
Weight	56 kg
Cable connection	2 x M20 cable glands
Ex approval	Eex e IIT6
Certificate	INERIS 03 ATEX 0102 X