



DIMENSIONS (m)

Modèle	300t	200t	150t
Ø: Diamètre	4	4	4
HHT: Hauteur hors tout	5,3	5	5
TE : Tirant d'eau	1,9	1,9	2
FB: Franc bord	1,2	1,2	1,2
A: Structure	4,7	4,2	4,7

SPÉCIFICATIONS

Modèle	300t	200t	150t
Poids (t)	4,79	4,42	4
Flottabilité (kg/cm)	124	124	124
CMU (t)	300	200	100
Applications	Haute mer, côtier, estuaire, port, rivière		
Structure	Acier peint		
Flotteurs	Polyéthylène basse densité UV 15		

*En fonction du mouillage prévu pour le(s) site(s).

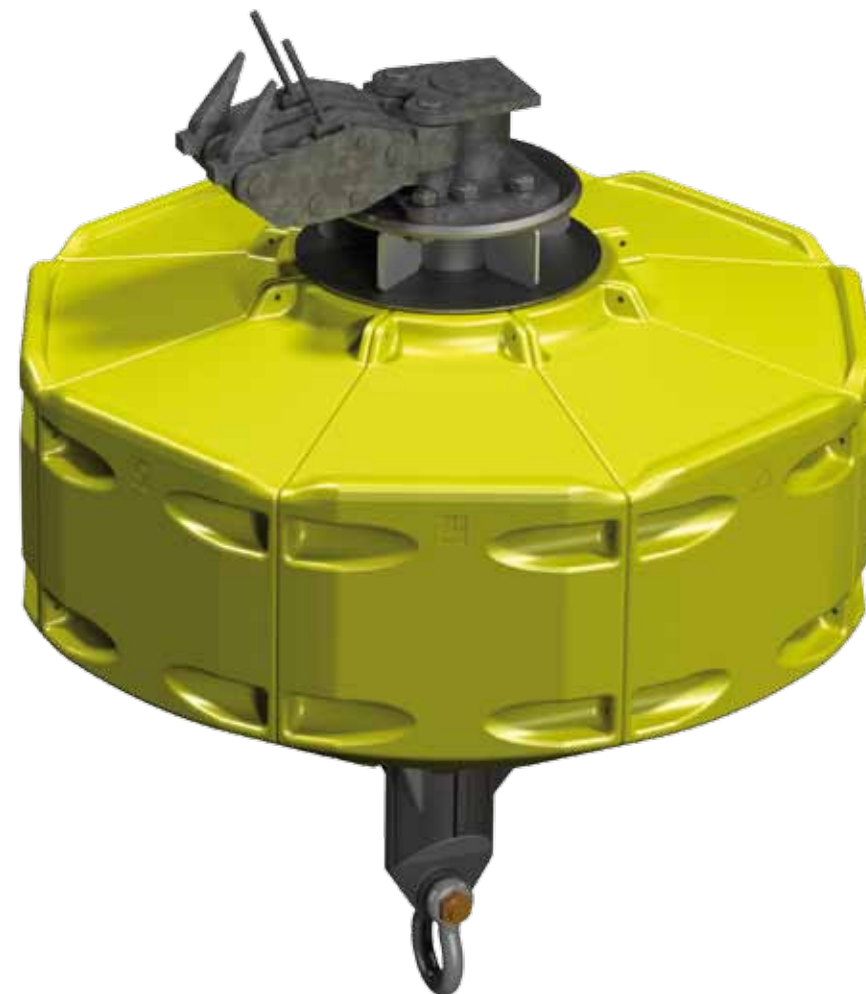

AMR 17000 2x100t QRH

Les éléments de mouillage (manilles, chaînes, émerillons, corps-morts) sont disponibles dans la section mouillage du catalogue.

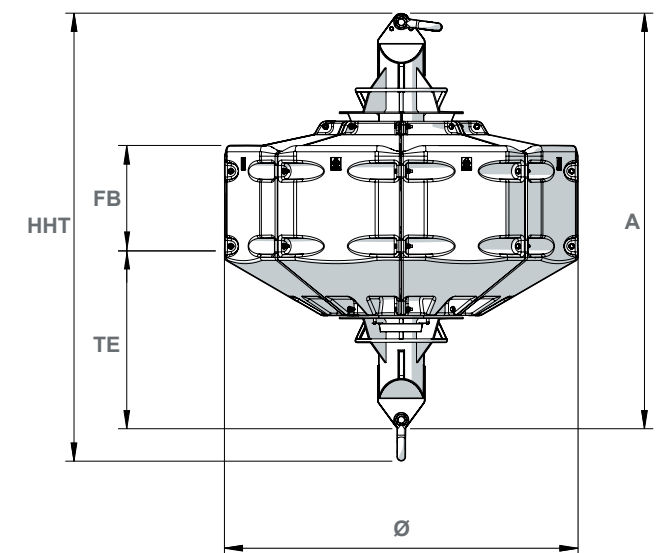
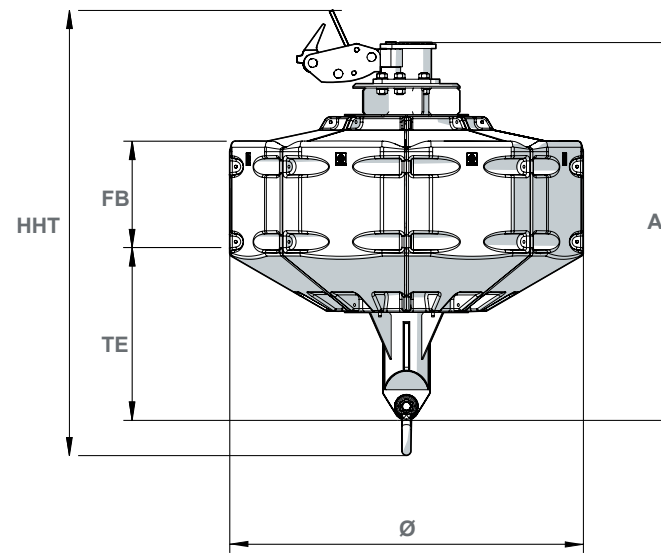
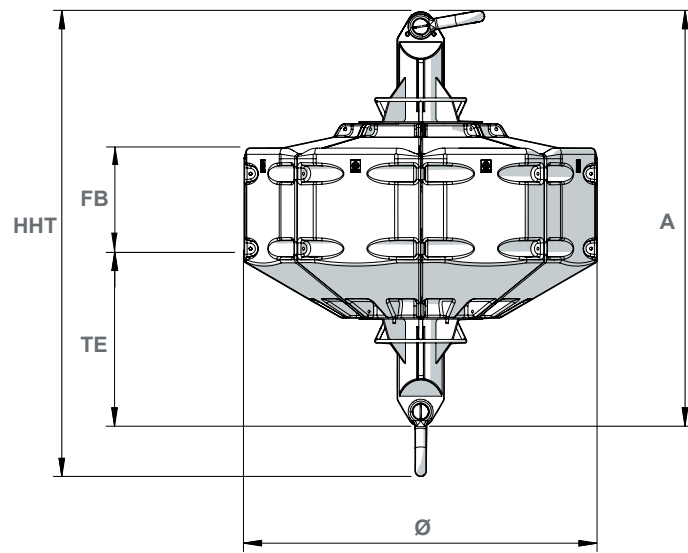

LIVRE AVEC SON BER DE TRANSPORT POUR L'ASSEMBLAGE ET STOCKAGE

AMR 17000 300t

AMR 17000 200t

AMR 17000 100t

Les photos et illustrations publiées sont non contractuelles.

MOORING BUOYS



DIMENSIONS (m)

Model	300t	200t	150t
Ø: Diameter	4	4	4
OH: Overall height	5,3	5	5
TE : Draught	1,9	1,9	2
FB: Freeboard	1,2	1,2	1,2
A: Structure	4,7	4,2	4,7

SPECIFICATIONS

Model	300t	200t	150t
Weight (t)	4,79	4,42	4
Buoyancy (kg/cm)	124	124	124
SWL (t)	300	200	100
Applications	High sea, coastal, estuary, ports, rivers		
Structure	Glassflake reinforced coated steel structure		
Floats	Low density polyethylene 15 years UV protected		

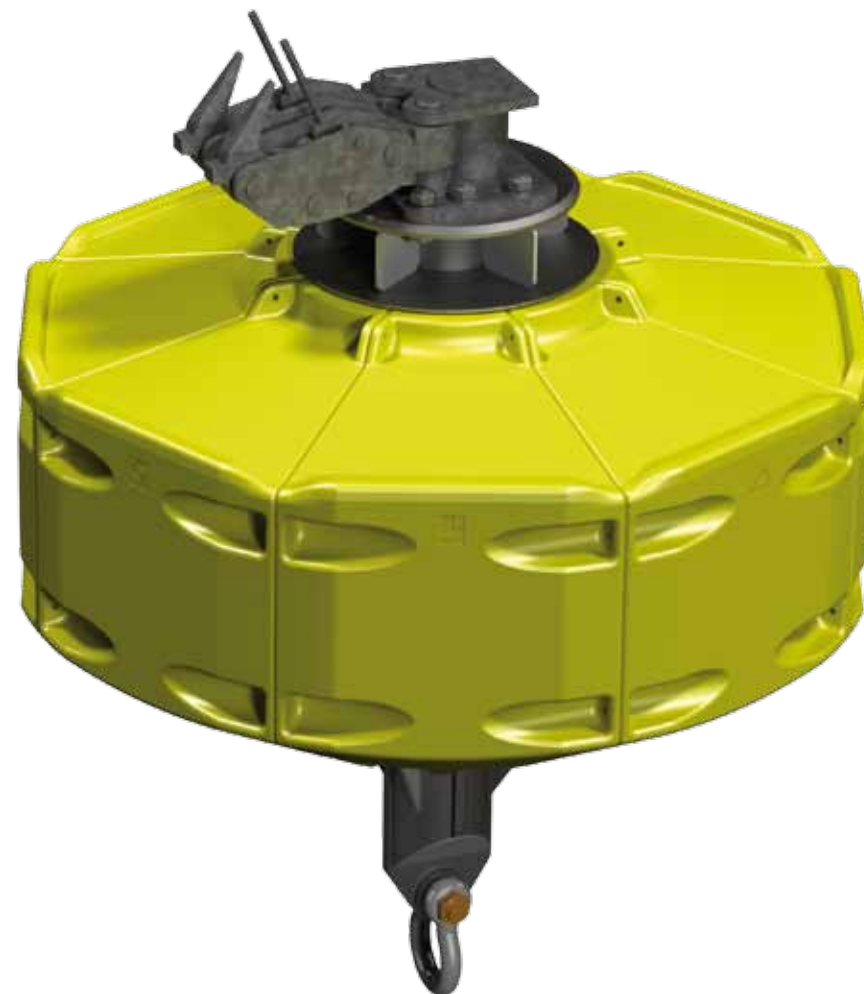

AMR 17000 2x100t QRH

Anchoring elements (skackles, chains, swivels, sinkers) are available in the mooring accessories section in the catalogue

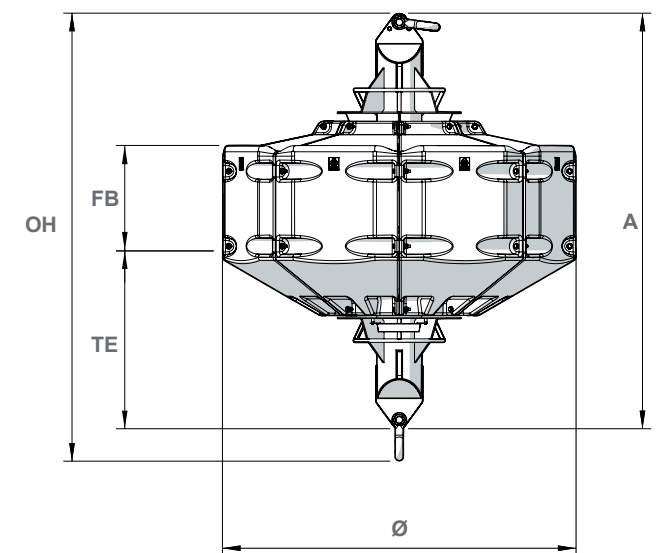
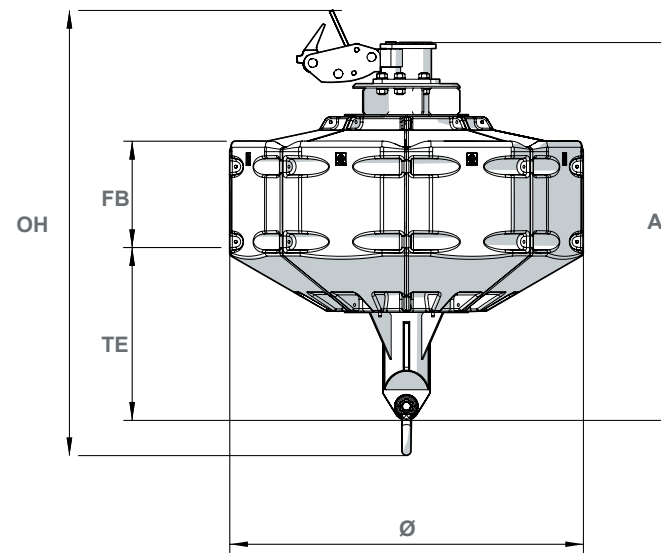
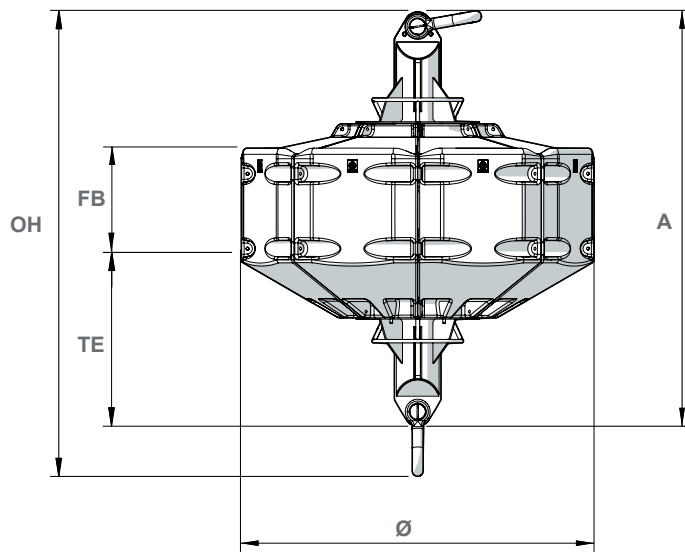

DELIVERED WITH ITS TRANSPORT CRADLE FOR ASSEMBLY AND STORAGE

AMR 17000 300t

AMR 17000 2x100t QRH

AMR 17000 150t

Non-contractual illustrations and photos